

## Single-point heat-tracing controller

### PRODUCT OVERVIEW



Elexant 4010i-SSR-FW

The nVent RAYCHEM Elexant 4010i is a compact, full-featured, touch screen based, single-point heat-tracing controller. It provides control and monitoring of Electric Heat Tracing (EHT) circuits for both freeze protection and process temperature maintenance. This controller can monitor and alarm on high and low temperature, high and low current, ground-fault levels, voltage, and supports a host of additional features to offer the utmost in control and monitoring of EHT.

The Elexant 4010i controller is available in two output types: an electromechanical relay (EMR) for use in nonhazardous locations, and a solid-state relay (SSR) for use in nonhazardous and Class I Div. 2 / Zone 2 hazardous locations. The controller is protected by a Fiber reinforced plastic or Stainless steel enclosure, both with front window (-FW or -SW). Multiple communication ports allow flexible connectivity for remote monitoring, configuration, and ease of integration with nVent RAYCHEM Supervisor software or a Distributed Control System (DCS).

### Control

The Elexant 4010i measures temperatures of up to three directly-connected temperature sensors. The controller also supports 4-20 mA inputs, allowing the use of external temperature sensor converters with thermocouples or other sensor types. The Elexant 4010i also features line sensing, ambient sensing, Proportional Ambient Sensing Control (PASC), and power limiting modes.

### Monitoring

A complete set of parameters are measured, including ground fault, temperature, current and voltage to ensure system integrity. The controller can be set to periodically check the heating cable for faults, alerting maintenance personnel of a heat-tracing problem eliminating costly manual maintenance checks.

A programmable dry contact alarm relay is provided for local or remote alarm annunciation.

### Installation



The Elexant 4010i comes ready to install, eliminating the need for custom panel design or field assembly. The IP6x rated FRP or stainless steel enclosures are approved for use in both indoor and outdoor locations. Wiring is as simple as connecting the incoming and outgoing power wiring (up to 277 Vac) and temperature sensors as needed for the application.

The Elexant 4010i provides an intuitive user interface that makes it easy to use and program. No additional programming devices are needed. Alarm conditions and programming settings are easy to read and interpret on the color touch screen. Settings are stored in non-volatile memory in the event of a power failure.

### Communication

Elexant 4010i units come equipped with RS485 and Ethernet ports and can be readily connected to a distributed control system (DCS). The units support both the Modbus RTU and Modbus/TCP protocols. The controller may be networked to a host PC running Windows-based nVent RAYCHEM Supervisor software for central programming, status review, and alarm annunciation.

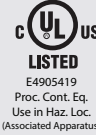
## GENERAL

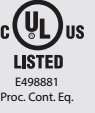
Area of Use	Nonhazardous locations (EMR versions) Nonhazardous and Class I, Division 2/Zone 2 hazardous locations (SSR versions)	
Approvals	Hazardous locations  Class I, Division 2, Group A,B,C,D T4 Type 4X Class I, Zone 2, AEx nA nC [ia Ga] IIC T4 Gc Ex ec nC [ia Ga] IIC T4 Gc IP64 (FW) IP66 (SW)  DEMKO 18 ATEX 2091 X IECEx UL 18 .0098X I13 (1)G Ex ec nC [ia Ga] IIC T4 Gc IP64 (FW) IP66 (SW)	Non-Hazardous locations  Enclosure Type 4X IP64 (FW) IP66 (SW)
	<b>I.S Temperature Sensor Inputs (Optional)</b> <b>Associated Apparatus</b> <b>Entity Parameters</b>	Um = 305VAC Uo = 5.4V Io = 0.083A Ca = 65uF La = 2mH
Electromagnetic Compatibility	IEC 61326-1:2012 / EN 61326-1:2013	
Supply voltage	100 Vac to 277 Vac, +/- 10%, 50-60 Hz	
Internal power consumption	< 24 W	

## ENVIRONMENTAL

Protection	Type 4X, IP64 (FRP enclosure) Type 4X, IP66 (stainless steel enclosure)
Materials	Fiber-Reinforced Plastic (FRP) or stainless steel (SS304)
Ambient operating temperature	-40°C to 60°C (-40°F to 140°F)
Ambient storage temperature	-55°C to 85°C (-67°F to 185°F)
Relative humidity	0% to 90%, noncondensing
Environment	PD2, CAT III
Max altitude	2,000 m (6,562 ft)

## CONTROL

Relay Type	Double-pole, mechanical (EMR versions) Double-pole, solid-state (SSR versions)
Voltage, maximum	277 Vac nominal, 50/60 Hz
Current, maximum	32 A @ 40°C, de-rated to 24 A @ 50°C and further de-rated to 16 A @ 60°C (EMR) 32 A @ 40°C, de-rated to 24 A @ 50°C and further de-rated to 16 A @ 60°C (SSR)
Control algorithms	EMR: On/Off, PASC, always on, always off SSR: On/Off, proportional, PASC, always on, always off
Control Range	-200°C to 700°C (-328°F to 1292°F)

**TYPICAL ENCLOSURE DIMENSIONS ([INCHES] MM)**

**Elexant 4010i-EMR-SW**

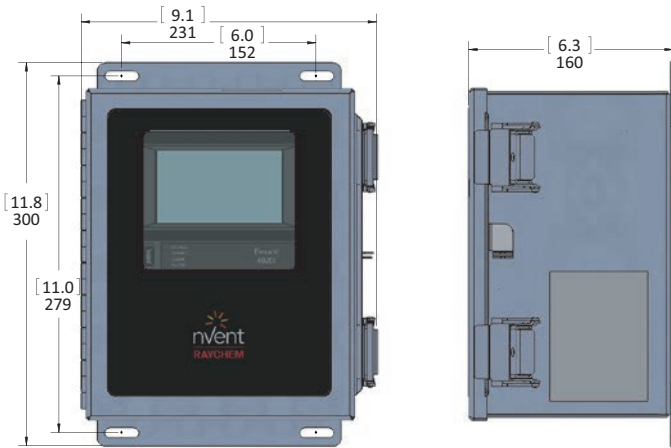

**Elexant 4010i-EMR-FW**

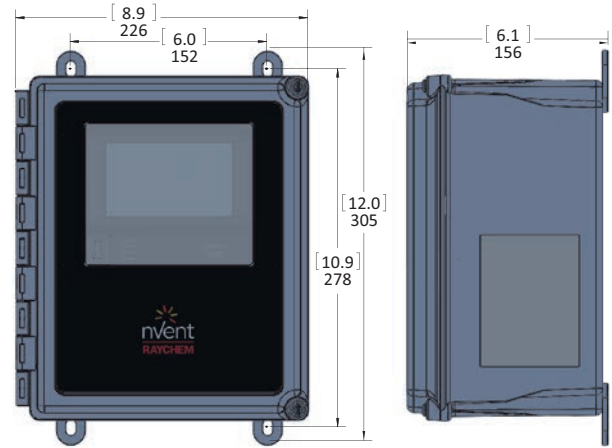

**Elexant 4010i-SSR-SW**

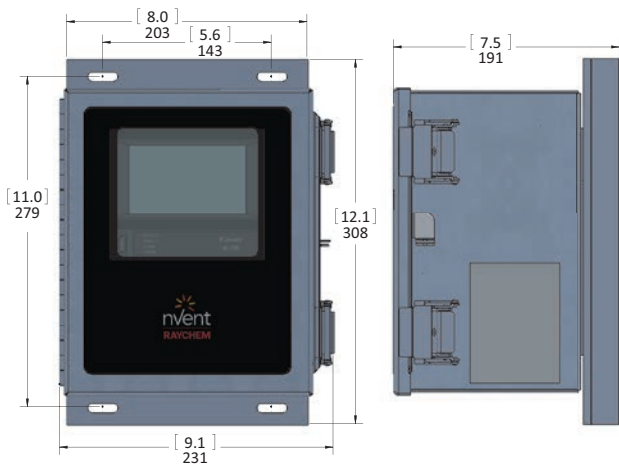

**Elexant 4010i-SSR-FW**

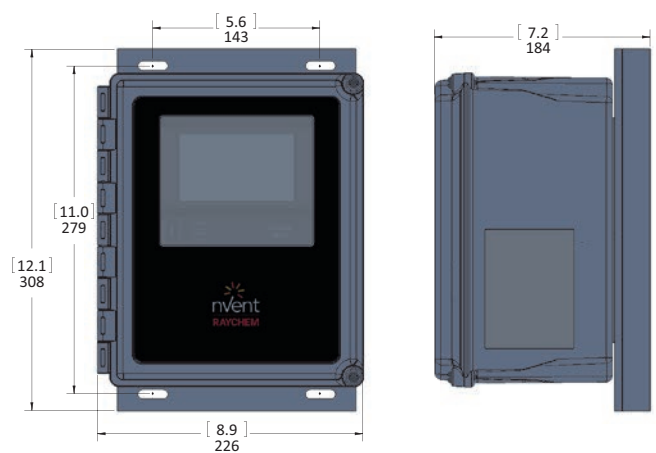

**MOUNTING**

FRP enclosure with EMR (EMR-FW)	Surface mounting with four holes on 152 mm x 278 mm (6.0 in x 10.9 in) centers Hole diameter: 8 mm (0.3 in)
FRP enclosure with SSR (SSR-FW)	Surface mounting with four holes on 143 mm x 279 mm (5.6 in x 11.0 in) centers Hole diameter: 8 mm (0.3 in)
SS enclosure with EMR (EMR-SW)	Surface mounting with four holes on 152 mm x 279 mm (6.0 in x 11.0 in) centers Hole diameter: 8 mm (0.3 in)
SS enclosure with SSR (SSR-SW)	Surface mounting with four holes on 143 mm x 279 mm (5.6 in x 11.0 in) centers Hole diameter: 8 mm (0.3 in)

**MONITORING**

Temperature	Low alarm range	-200°C to 700°C (-328°F to 1292°F) or OFF
	High alarm range	-200°C to 700°C (-328°F to 1292°F) or OFF
Ground fault	Alarm range	10 mA to 500 mA or OFF
	Trip range	10 mA to 500 mA or OFF
Current	Low alarm range	0.1 A to 100 A or OFF
	High alarm range	0.1 A to 100 A or OFF
	Power limit range	8 W to 30 kW
Voltage	Low alarm range	80 Vac to 300 Vac or OFF
	High alarm range	80 Vac to 300 Vac or OFF
Resistance	Low resistance range	1% to 100% of deviation from nominal
	High resistance range	1% to 250% of deviation from nominal
Autocycle	Diagnostic test interval	1 to 750 hours

## TEMPERATURE SENSOR INPUTS

Quantity 3  
Each can be individually set to one of the types below.

### Types

100Ω platinum RTD	3-wire, $\alpha=0.00385$ ohms/ohm/°C –200°C to 700°C (–328°F to 1292°F), $\pm 1^\circ\text{C}$ Can be extended with a 3-conductor shielded cable of 20Ω maximum per conductor
100Ω nickel iron RTD	2-wire, $\alpha=0.00599$ ohms/ohm/°C –73°C to 350°C (–99°F to 662°F), $\pm 1^\circ\text{C}$ Can be extended with a 2-conductor shielded cable of 20Ω maximum per conductor
100Ω nickel RTD	2-wire, $\alpha=0.00618$ ohms/ohm/°C –70°C to 250°C (–94°F to 482°F), $\pm 1^\circ\text{C}$ Can be extended with a 2-conductor shielded cable of 20Ω maximum per conductor
Thermocouple	Requires external 4-20 mA converter 4-20 mA current loop, $\pm 0.05$ mA, 24 Vdc loop power

The Elexant 4010i-IS variants are equipped with intrinsic safety barriers at the RTD inputs.

### RTD Intrinsic Safety Associated Apparatus Entity Parameters

Uo (Maximum Output Voltage): 5.4 V	La (Maximum External Inductance): 2 mH
Io (Maximum Output Current): 0.083 A	Ca (Maximum External Capacitance): 65 uF
Po (Maximum Output Power): 0.449 W	

## DIGITAL INPUTS

Quantity	Two multi-purpose inputs for connection to external dry (voltage free) contact or DC voltage May be configured for Hand-Off-Auto (HOA) operation
Rating	100Ω max loop resistance or 5-24 Vdc @ 1 mA maximum

## OUTPUTS

Alarm Relay	Form-C dry contact: 00 Vac to 277 Vac, 3 A 50/60 Hz
Auxiliary Output	24 Vdc, max load of 250 mA @ 40°C, de-rated to 165 mA @ 60°C

## CONFIGURATION

Method	Touch screen display
Units	°F or °C
Idle display	Sensor temperature, control temperature, heater current, voltage, power, alarm status
LEDs	Status, heater on, alarm conditions, receive / transmit data
Memory	Nonvolatile, restored after power loss, checksum data checking
Stored usage parameters	Minimum and maximum process temperature, maximum ground-fault current, minimum and maximum voltage, maximum heater current, power accumulator, contactor cycle count, total time in use, heater on time
Alarm conditions	Low / high temperature, low / high current, low / high voltage, low / high resistance, ground-fault alarm / trip, RTD failure, loss of programmed values, EMR or SSR failure, equipment protection trip, attached device alarm, contactor lifetime exceeded
Alarm Modes	Normal (solid on), flash (on & off), toggle (re-ring new alarms)
Control Algorithms	EMR: On/Off, PASC, always on, always off SSR: On/Off, proportional, PASC, always on, always off
Equipment Protection	Ground fault trip, low / high temperature limit, Soft-Start features, (heat trace output limiting, SSR overcurrent protection, circuit breaker nuisance trip prevention)
Load Shedding	Up to 8 zones, with temperature failsafe and communication timeout (requires nVent RAYCHEM Supervisor)
Profiles	Built-in default setting profiles for common heat trace applications Up to two additional user configurations can be saved and reloaded. Saved configurations can be saved to, and loaded from, a USB thumb drive

Network	Automatic network configuration with DHCP, or static IP configuration
Firmware Updates	User updateable using a USB thumb drive
Multi-language Interface	English, French, German, Spanish, Russian
Other	Password protection, text tags / identifiers for controller and temperature sensors

## CONNECTION TERMINALS

Power supply input	Screw terminals, 0.2 – 16.8 mm <sup>2</sup> (24 – 5 AWG)
Heating cable output	Screw terminals, 0.2 – 16.8 mm <sup>2</sup> (24 – 5 AWG)
Torque range for screw terminals	1.2 – 1.5 Nm
Ground (Earth)	Three box lugs, 2.0 – 33.6 mm <sup>2</sup> (14 – 2 AWG)
Sensor / Other terminals	Cage clamp terminals, 0.08 – 3.3 mm <sup>2</sup> (28 – 12 AWG)

## CABLE ENTRIES

Fiberglass enclosure	3 x M16	for temperature sensors, 2 x stopping plugs and 1 x rain plug
	2 x M20	For communication and/or alarm relay, all with stopping plugs
	2 x M25	1 x gland (GL-55-M25), Ø 8-15 mm for power cable in 1 x rain plug for heat-tracing cable out
Stainless steel enclosure	3 x M16	for temperature sensors, 2 x stopping plugs and 1 x rain plug
	2 x M20	For communication and/or alarm relay, all with stopping plugs
	2 x M25	2 x rain plugs for power cable in and heat-tracing cable out

## COMMUNICATIONS

### RS-485

Type	2-wire RS-485
Cable	One shielded twisted pair
Length	1,200 m (4,000 ft.) maximum
Quantity	Up to 247 devices per port
Data Rate	9600, 19.2k, 38.4k, 57.6k baud
Parity	None, even, odd
Stop bits	0, 1, 2
Tx delay	0 – 5 seconds
Protocol	Modbus RTU

### Ethernet

Type	10/100 Base-T
Length	100 m (328 ft) max
Data rates	10 or 100 MB/s
Protocol	Modbus/TCP, DHCP
Connection terminals	Shielded 8-pin RJ-45

## ORDERING DETAILS

Description	Catalog number	Part number	Weight (kg/lbs)
<b>Elxant 4010i controller</b> in an 20 cm x 25 cm <b>FRP</b> enclosure with window. Controls a single circuit with a 2-pole electromechanical relay (32 A EMR). Includes <b>intrinsically safe</b> barriers on RTD inputs with power cable gland.	10380-009	4010i-EMR-IS-FW (EMEA)	4.6/10.2
(Approved for nonhazardous locations only. RTDs may be placed in Zone 0/Zone 1/Zone 2 locations)			
<b>Elxant 4010i controller</b> in an 20 cm x 25 cm <b>stainless steel</b> enclosure with window. Controls a single circuit with a 2-pole electromechanical relay (32 A EMR). Includes <b>intrinsically safe</b> barriers on RTD inputs with power cable gland.	10380-011	4010i-EMR-IS-SW (EMEA)	6.6/14.6
(Approved for nonhazardous locations only. RTDs may be placed in Zone 0/Zone 1/Zone 2 locations)			
<b>Elxant 4010i controller</b> in an 20 cm x 25 cm <b>FRP</b> enclosure with window. Controls a single circuit with a 2-pole solid-state relay (32 A SSR). Includes <b>intrinsically safe</b> barriers on RTD inputs with power cable gland.	10380-010	4010i-SSR-IS-FW (EMEA)	6.6/14.6
(Approved for Zone 2 hazardous locations. RTDs may be placed in Zone 0/Zone 1/Zone 2 locations)			
<b>Elxant 4010i controller</b> in an 20 cm x 25 cm <b>stainless steel</b> enclosure with window. Controls a single circuit with a 2-pole solid-state relay (32 A SSR). Includes <b>intrinsically safe</b> barriers on RTD inputs with power cable gland.	10380-012	4010i-SSR-IS-SW (EMEA)	8.6/19.0
(Approved for Zone 2 hazardous locations. RTDs may be placed in Zone 0/Zone 1/Zone 2 locations)			
<b>RTD Sensors</b>			
Temperature Sensor with 2 m flexible cable and M16 gland, Pt100	MONI-PT100-260/2	1244-006615	0.14/0.3
Temperature Sensor with 5 m flexible cable and M16 gland, Pt100	MONI-PT100-260/5	1244-020817	0.35/0.8
Temperature Sensor with 10 m flexible cable and M16 gland, Pt100	MONI-PT100-260/10	1244-020816	0.7/1.5
Temperature Sensor with 2 m MI Cable and Junction Box, Pt100, ATEX	MONI-PT100-EXE	967094-000	0.5/1.1
Temperature Sensor with 2 m MI Cable and M16 gland, Pt100, ATEX	MONI-PT100-EXE-SENSOR	529022-000	0.13/0.3
<b>nVent RAYCHEM Supervisor Software</b>	<b>Available for download at <a href="http://www.nVent.com">www.nVent.com</a></b>		

### North America

Tel +1.800.545.6258  
 Fax +1.800.527.5703  
[thermal.info@nVent.com](mailto:thermal.info@nVent.com)

### Europe, Middle East, Africa

Tel +32.16.213.511  
 Fax +32.16.213.604  
[thermal.info@nVent.com](mailto:thermal.info@nVent.com)

### Asia Pacific

Tel +86.21.2412.1688  
 Fax +86.21.5426.3167  
[cn.thermal.info@nVent.com](mailto:cn.thermal.info@nVent.com)

### Latin America

Tel +1.713.868.4800  
 Fax +1.713.868.2333  
[thermal.info@nVent.com](mailto:thermal.info@nVent.com)



Our powerful portfolio of brands:

**CADDY ERICO HOFFMAN RAYCHEM SCHROFF TRACER**