

Factory-Welded Joints

Installation Instructions for Pulling and Supporting Factory-Welded Joints

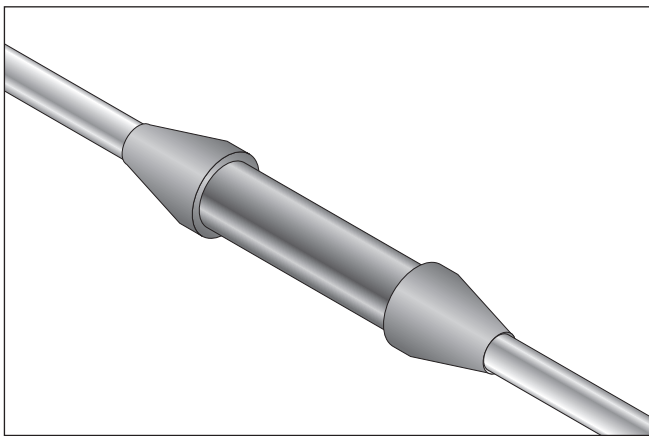

DESCRIPTION

Pyrotenax Factory-Welded Joints are supplied when the circuit length exceeds the nominal coil length of a particular cable configuration. Reinforcing sleeves are affixed at both ends of every joint to avoid damage to the welds when the cable is pulled into position. Factory-welded Joints for fire-rated applications have been tested to UL 2196 and ULC-S139 and carry a 2-hour fire rating that requires no additional protection.

Note: For fire-rated applications, Factory-Welded Joints are only available for cable diameters of 0.402 in (10.2 mm) and larger.

APPROVALS

Nonfire-rated



2-hour fire-rated

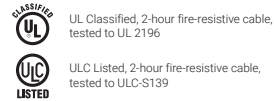

Maximum Allowable Pulling Tension (LBS)

Pyrotenax System 1850 and System 1850-SE cables

Cable reference	Cable size (AWG/kcmil)	Pulling Tension		Cable reference	Cable size (AWG/kcmil)	Pulling Tension	
		Cable only (lbs)	Cable with joints (lbs)			Cable only (lbs)	Cable with joints (lbs)
1/500-1000	500	4200	2200	2/10-449	10	500	500
1/350-834	350	3000	2200	2/12-402	12	350	350
1/250-746	250	2300	2200	2/14-371	14	300	300
1/4/0-684	4/0	2000	1500	2/16-340	16	220	220
1/3/0-621	3/0	1600	1500	3/3-834	3	1900	1900
1/2/0-580	2/0	1300	1300	3/4-746	4	1500	1500
1/1/0-512	1/0	1100	1100	3/6-621	6	1000	1000
1/1-496	1	900	900	3/8-590	8	700	700
1/2-449	2	750	750	3/10-480	10	500	500
1/3-449	3	640	640	3/12-480	12	400	400
1/4-402	4	520	520	3/14-387	14	310	310
1/6-340	6	370	370	3/16-355	16	240	240
1/8-298	8	260	260	4/6-730	6	1300	1300
1/10-277	10	200	200	4/8-590	8	900	900
1/12-246	12	170	170	4/10-590	10	600	600
1/14-230	14	140	140	4/12-465	12	500	500
1/16-215	16	100	100	4/14-465	14	420	420
2/1-975	1	2300	2200	4/16-387	16	290	290
2/2-865	2	1800	1800	7/8-710	8	1200	1200
2/3-768	3	1450	1450	7/10-621	10	1000	1000
2/4-684	4	1100	1100	7/12-543	12	700	700
2/6-590	6	800	800	7/14-496	14	500	500
2/8-512	8	600	600	7/16-449	16	400	400

Pulling the Joint

- Do not pull the joint over a pulley or sheave. Manually pass the cable with the joint beyond the pulley/sheave first, taking care not to bend the cable at the joint ends. Bend the cable around the pulley/sheave, by hand, and continue pulling once the joint is past the pulley/sheave.

 **Important: To avoid damaging the joint, do not pull the joint directly over a sheave or pulley.**

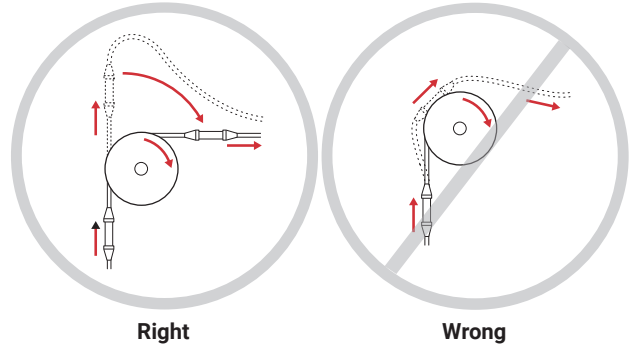

Fastening the Joint

- When fastening the joint to a wall or ceiling, support the joint using the banding and bracket system available from Chemelex. Further details on the banding and bracket system, and support spacing for the cable on either side of the joint, can be found in the Commercial MI Wiring Cable Installation Manual (H58764). The joint must be supported at its center and 39 in (1 m) on either side of this support as shown below.
- When using any other method to support fire-rated cables, such as a trapeze system, stagger the joints if possible and ensure that each joint is firmly supported. This can be accomplished by supporting each joint with additional trapeze supports or by securing the joint on top of a section of steel channel and firmly attaching the channel between existing trapeze supports.

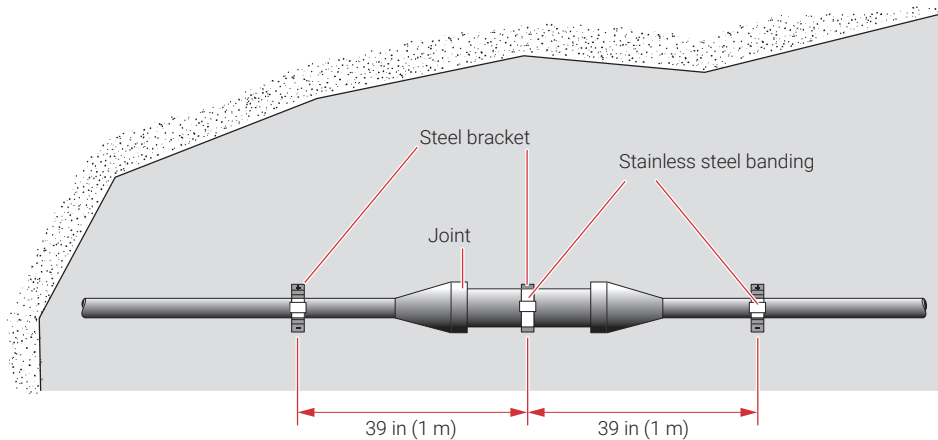

North America

Tel +1 800 545 6258
info@chemelex.com

Europe, Middle East, Africa, India

Tel +32 16 213 511
Fax +32 16 213 604
info@chemelex.com

Asia Pacific

Tel +86 21 2412 1688
infoAPAC@chemelex.com

Latin America

Tel +1 713 868 4800
info@chemelex.com

chemelex
excellence is everything

Raychem

Tracer

Pyrotenax

Nuheat